

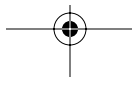

MODEL 480i

INSTALLATION GUIDE

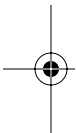



480i E Cover.fm Page 0 Tuesday, May 18, 2004 12:03 PM





Table of Contents

Table of Contents

Introduction 1

- Phone Features 1
- Requirements..... 1
- About This Guide 1
- Phone Parts2
- Optional Accessories2

Key Description3

Installation and Setup.....5

- Direct or Shared Network Connection5
- Connecting to the Network and to Power6
- Connecting a Handset or Headset.....7
- Desk or Wall Installation.....7

Customizing your phone.....9

- Setting your Options.....9

Other Phone Features 10

- Adjusting the Volume 10
- Status Lights 11
- Timer..... 11
- Softkeys 11
- Using a Headset with your Telephone..... 11
- Using Services 11

Troubleshooting 12

Limited Warranty 13

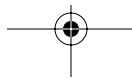

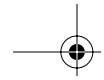

Introduction

Introduction

Congratulations on your purchase of the Model 480i IP telephone!

The 480i communicates over an IP Network, allowing you to receive and place calls in the same manner as a regular business telephone. The 480i is capable of supporting MCGP, SIP and H.323 IP protocols.

Phone Features

- A large backlit display
- 6 multi-functional softkeys
- 4 call appearance lights with corresponding buttons*
- Enhanced busy lamp fields*
- Set paging*
- A speakerphone for handsfree calls
- Built-in-two-port, 10/100 Ethernet switch. Lets you share a connection with your computer.
- Inline power support eliminates power adapters.

* Availability of feature dependant on your phone system or service provider

Requirements

- 802.3 Ethernet/Fast Ethernet LAN
- Category 5/5e straight through cabling
- A PoE (Power over Ethernet) inline power supply, necessary only if your network does not provide 802.3af compliant in-line power (optional accessory)
- Phone system or service provider that supports the 480i

About This Guide

This manual describes how to physically set up your new 480i. Not all features listed are available by default and some may depend on your phone system or service provider. Contact your Network Administrator if you have any questions on what features and services are available to you on your system.

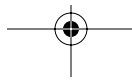



Phone Parts

When you unpack your phone, you should ensure that you have all of the following items. If any part is missing, contact the supplier of your phone.

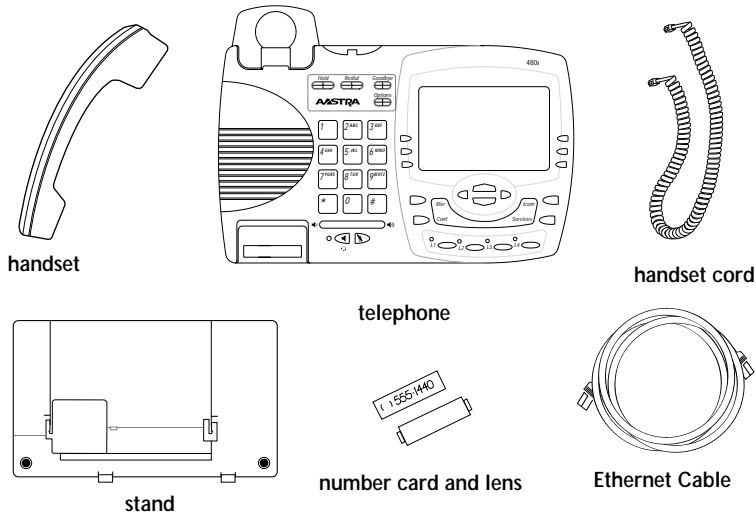

Optional Accessories (Not Included)

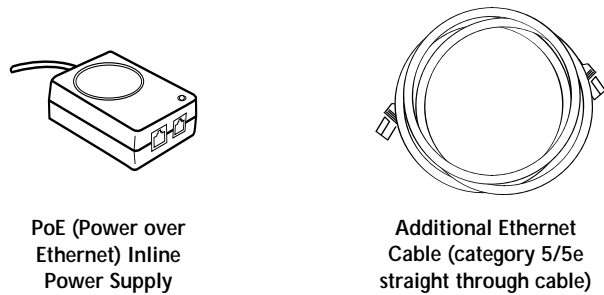

A PoE (Power over Ethernet) inline power adapter supplies 48v power to the **480i** through the Ethernet Cable on pins 1 & 2 and 3 & 6. Do not use this power supply to power other devices.

- **Voltage:** 110/120 V AC in; 48 V DC out
- **Safety and emissions:** Canada: ICES-003 Class A; Japan: VCCI Class A; U.S.: FCC Class A, CSA, C-Tick, NOM









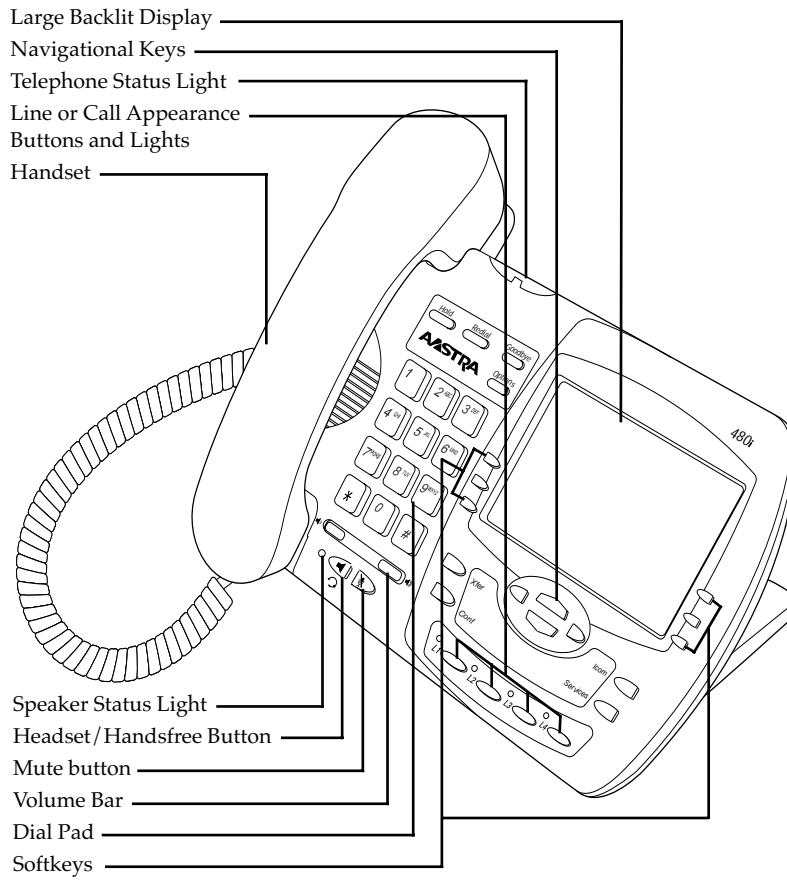







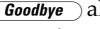



















Key Description

Key Description



Key Description

Keys	Key Description
	Places an active call on hold. To retrieve a held call, press the call appearance button beside the light that is flashing.
	Redials up to ten previously dialed numbers.
	Pressing  ends an active call.  also exits an open list, such as  , without saving changes.
	The  button lets you access options to customize your phone. Your Network Administrator may have already customized some of your settings. Check with your Network Administrator before changing any Network Administrator only sections.
	Adjusts the volume for the handset, headset, ringer and handsfree speaker. See the section “ Adjusting the Volume ” for more information.
	Pressing  activates Handsfree so you can make and receive calls without lifting the handset. When the audio mode option is activated, this key is used to switch between a headset and the Handsfree speakerphone. See the section “ Customizing your phone ” for more information.
	Pressing  prevents the caller from hearing you through the handsfree, handset or headset microphone. The speaker light blinks quickly to indicate mute is active. To unmute, press  again.
	Pressing  transfers the active call to another number. * See your 480i Operating Guide for further information.
	Pressing  begins a conference call with the active call. * See your 480i Operating Guide for further information.
	Pressing  and  lets you move between screens. These buttons also let you scroll through menu selections, such as the Options List. Pressing  and  in the options list will also cancel or show the current option. When you are editing entries on the display,  moves the cursor left and  moves the cursor right.
	Pressing  begins an intercom call to an extension on the system. * See your 480i Operating Guide for further information.
	Pressing  opens Services that are available to your phone, if Services have been configured. *
   	Pressing one of the line or call appearance buttons connects you to a line or call. * See your 480i Operating Guide for further information.

*Availability of feature dependant on your phone system or service provider



Installation and Setup

The 480i can be setup to share a network connection with another network device. Power can be provided by an 802.3af compliant network power source or with a PoE inline power supply (optional accessory). It can also be installed on a desk or mounted on the wall. If your Network Administrator has already setup your phone, please refer to the 480i Operating Guide (if provided) for call handling information or talk to your Network Administrator.

Direct or Shared Network Connection

The phone can be set up as a direct network connection to the Ethernet wall jack or as a shared network connection as a pass-through if connecting the phone to a computer or another network device.

Direct Network Connection

Located at the back of the phone are two fully switched 10/100 Mbps Ethernet cable ports. The port marked with  is used to connect the phone to the network, as well as provide power to your phone. See the section "Connecting to the Network and to Power" for more information.

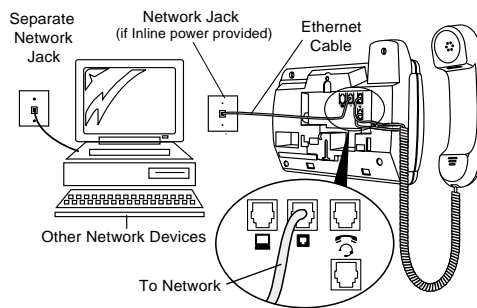

Shared Network Connection

To connect a network device (such as a computer) to the phone, connect an Ethernet Cable into the network port on the back of the phone marked with . Plug the other end of the Ethernet Cable into the network jack on the network device you are sharing the network connection with.

Note: The  jack on the 480i does not supply inline power onto other network devices.

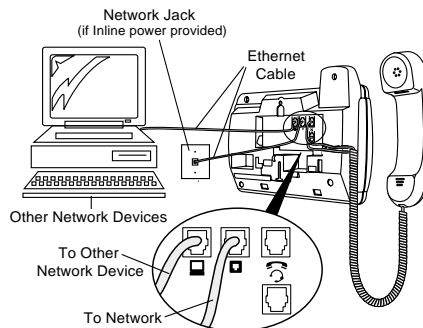

Note: All Ethernet cables used must be category 5/5e straight-through cables, such as the cable provided with your phone

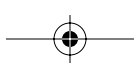

Connecting to the Network and to Power

Inline Power Provided

If your network provides 802.3af compliant in-line power, the phone will be provided with power through the network.

1. On the back of your phone, connect the Ethernet Cable (provided with your phone) into the network port marked with .
2. Plug the other end of the Ethernet Cable directly into the network jack on the wall.

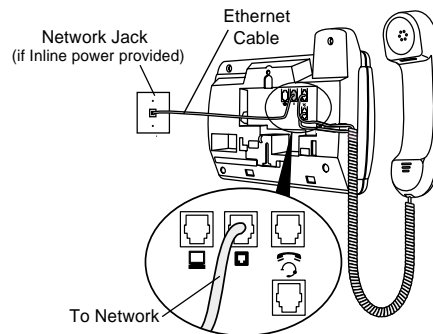

Inline Power Not Provided

If your network does not provide 802.3af compliant in-line power, you will need to install the PoE inline power supply (optional accessory).

1. On the back of your phone, connect the Ethernet Cable (provided with your phone) into the network port marked with .
2. On the PoE power supply, plug the other end of the Ethernet Cable into the network jack marked as indicated below.
3. On the PoE power supply, connect an additional Ethernet Cable (provided with the power supply) into the network port as indicated below.
4. Plug the other end of the Ethernet Cable into the network jack on the wall.
5. Plug the PoE power supply into a power outlet.

Note: You should connect the power supply to a surge protector or power bar.

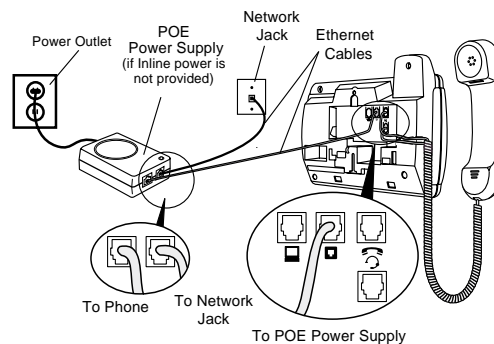

Note: All Ethernet cables used must be category 5/5e straight-through cables, such as the cable provided with your phone.

Connecting a Handset or Headset

Handset

Turn the phone over and locate the handset jack marked . Insert one end of handset cord into the jack until it clicks into place. Then route the handset cord through the upper groove as shown in the next illustration. Attach the handset to the other end of the handset cord.

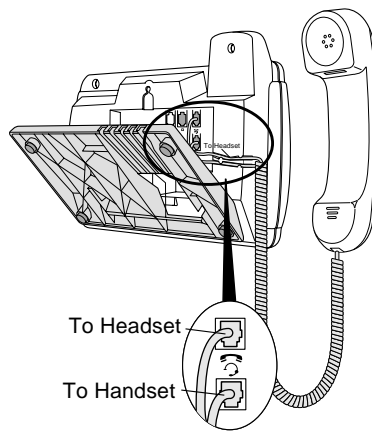



Headset (Optional)

Turn the phone over and locate the headset jack marked . Insert the headset cord into the jack until it clicks into place. Then route the headset cord through the lower groove as shown in the previous illustration.

Desk or Wall Installation

Install on the Desk

Route the cables through the opening in the stand. Attach the stand by inserting the tabs on the stand (marked with ) into the slots on the bottom of the phone. For a higher viewing angle, use the slots marked .

For a lower viewing angle, use the slots marked . Then push the stand towards the phone until it snaps into place. Press the cords into the grooves provided on the bottom of the stand. This will allow the stand to sit flat on a desk surface.

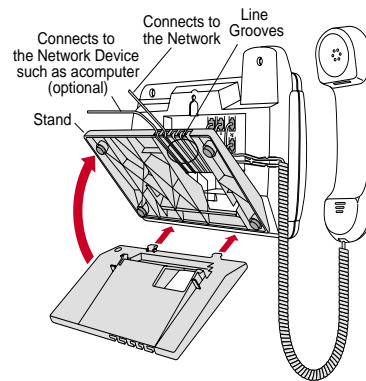

Install on the Wall

Connect the Ethernet cable to the wall network jack (A). Coil the cable into the space provided on the back of the phone (B). Then align the phone so the hooks on the wall plate (C) align with the wall-mount slots on the back of the phone, as shown here. Push the phone onto the pegs, and then slide it down until it is secure (D).

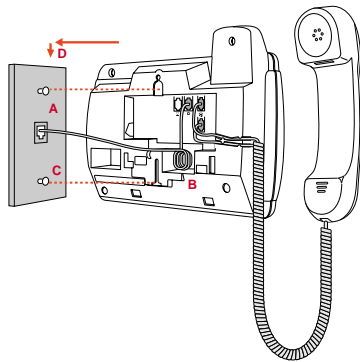

Note: You may wish to purchase a short Ethernet cable from a local supplier for a wall installation. Also, if 802.3af compliant in-line power is not provided on your network and you are installing the 480i on a wall using a PoE in-line power supply, you may also wish to use an equivalent flat Ethernet cable rather than the one provided.

Inserting Number Card

Write your phone number on the number card, and place it into the card slot on the phone, located under the mouthpiece in the handset cradle. Gently bend the clear plastic lens into the slot, over the number card.

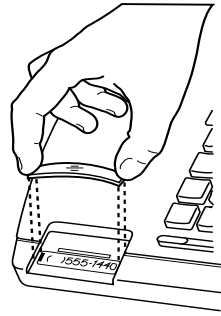

Customizing your phone

There is a list of configuration options, accessed by pressing the **Options** button.

Setting your Options

1. Press **Options** to enter the Options List.
2. Use **▼** and **▲** to scroll through the list of options.
3. Press the **Show** softkey, the **▶** button or press the digit number of the corresponding option to select an option.
4. Use the softkeys to change a selected option.
5. Press the **Done** softkey at any time to exit the option and save the change.
6. Press the **Cancel** softkey, the **◀** button or the **Goodbye** button at any time to exit without saving changes.

The following options may change on the 480i:

1. Language

Select a language for the display prompts.

Note: Supported languages may vary.

2. Time and Date

Use these options to set the local time on the phone. Depending upon the configuration, time set here may be overwritten by the time on your phone system. If you are having problems with this, contact your Network Administrator.

A) Timeserver

Talk to your Network Administrator before making changes to this option.

If the Timeserver option is enabled, the display shows the IP address where the phone is getting time and date

information from on the Network. Whenever the phone starts up, it will automatically attempt to find the Timeserver. If the Timeserver is not found and unknown to the phone, the IP address will display as 0.0.0.0, and the time and date in the main screen will display the equivalent of "12:00 am Jan. 1st 2000". If the time server option is disabled, the display shows "Network Time Disabled". You can set the time and date manually on your phone.

B) Set Time

This option shows the Network time, if the Timeserver option is enabled. If the Timeserver is not enabled, this option allows you to enter the time manually.

C) Time Format

Select a time format for how time will be displayed on your phone (12h or 24h clock).

D) Set Date

This option shows the Network date, if the Timeserver option is enabled. If the Timeserver is not enabled, this option allows you to enter the date manually.

E) Date Format

Choose from a list of formats for how date will be displayed on your phone.

F) Timezone

Choose your current time zone from a list of time zones.

G) Daylight Savings

This option allows you to specify daylight savings.

3. Set Ring Tone

Press the **Change** softkey to select one of the four ring tones. Use the volume bar to increase or decrease the ringer volume level.

4. Clear Message Waiting

To clear the Message Waiting Light, select the **Clear** softkey. The light will flash again when there are new messages waiting.

5. Contrast Level





Use the **Change** softkey to cycle through 8 contrast settings, which brighten or darken the display.





6. Live Dial Pad*

Use this option to turn on or off the dial pad mode. With live dial pad on, the telephone automatically dials out and turns on Hands free mode as soon as a dial pad key or softkey is pressed. With live dial pad off, you must dial the number first and then lift the handset or press the Handsfree button before the number is dialed. Press the **Change** softkey to turn on or off the dial pad mode.

7. Set Audio

The 480i allows you to use a handset, a headset or handsfree to handle incoming and outgoing calls. This option provides different combinations of these three methods to provide maximum flexibility in handling calls. There are four options to choose from:

- **Handsfree** — this is the default setting. Calls can be made or received using the handset or handsfree speakerphone and can be switched between the two modes by pressing the  /  button on the phone. When on handsfree, you can return to using the handset by placing the handset on the cradle and picking it up again.
- **Headset** — choose this setting if you want to make or receive all calls using a headset. Calls can be switched between the headset and handset by pressing the  /  button on the phone.

- **Spkr/Hset** — incoming calls will be sent to the handsfree speakerphone. By pressing the  /  button on the phone you can switch between the handsfree speakerphone, the headset and the handset.
- **Hset/Spkr** — calls will be sent to the headset. By pressing  /  the button on the phone you can switch between the headset, the handsfree speakerphone and the handset.

Further settings in the options menu are specific to the firmware version you have in your phone. Further information about this option can be found in the 480i Operating Guide and the 480i Administrator Guide.

Talk to your Network Administrator before changing any of these settings.



*Availability of feature dependant on your phone system or service provider

Other Phone Features

Adjusting the Volume

Pressing the volume button  adjusts the receiver, headset, speaker, and ringer volume.

- To adjust the ringer volume, leave the handset in the cradle and press the volume button  while there is no active call. There are 8 settings for the ringer — the display will temporarily indicate the current ringer volume setting.
- To adjust the handset volume, lift the handset and press the volume button while you are on a call. The handset will remain at this volume until it is adjusted again.

- To adjust the headset volume, press the volume button while you are on a call. The headset will remain at this volume until it is adjusted again.
- To adjust the speaker volume, press the volume button while the speaker is activated (activate the speaker by pressing  / ). The speaker will remain at this volume until it is adjusted again.

Status Lights

Speaker Light

- Speaker light is on solid: a call is on Handsfree (speakerphone).
- Speaker light flashes slowly: indicates that the headset is being used.
- Speaker light flashes quickly: indicates that the call is muted. Press  to take the call off mute.

Telephone Light

- Light flashes slowly: indicates you have messages.
- Light flashes quickly and the ringer sounds: indicates you have an incoming call.

Timer

- When you make or answer a call, the Timer shows the elapsed time of the call.



Softkeys

The 480i has 6 softkeys that can be programmed to make call handling and managing calls easier. This phone uses softkeys to give you commands to choose from. Each choice corresponds to the button next to it.

Using a Headset with your Telephone

The 480i accepts headsets through the modular RJ22 jack on the back of the phone. Contact your telephone equipment retailer or distributor to purchase a compatible headset. Customers should read and observe all safety recommendations contained in headset operating guides when using any headset.

Making and Receiving Calls using a Headset

1. Ensure that you have selected a headset audio mode by accessing the Options menu. See the section “Customizing your phone” for detailed information.
2. Plug the headset into jack.
3. Press the  /  key to obtain dial tone or answer an incoming call. Depending on the audio mode selected from the Options menu, dial tone or an incoming call will be received on either the headset or the handsfree speakerphone.
4. Press the  key to end the call.

Using Services

The Services key on the 480i can access enhanced features and services provided by third parties. Check with your system administrator on how to configure this button. Availability of this feature is dependant on your phone system or service provider.

Troubleshooting

What are services, and how do I use them?

Services are provided by your phone system or service provider, and can be accessed through the **Services** key. This may include services such as Directory and Caller's List. See the section **"Using Services"** or check with your system administrator for more information.







Why is the light not coming on with a new Voice Mail Message?

Your phone system or service provider must provide "Visual" Message Waiting service for this function to work. Check with your system administrator for more information.

Why is my handset not working?

Check to ensure that the handset cord is fully connected to both the phone and handset. See the section **"Connecting a Handset or Headset"** for information.

Why is my speakerphone not working?

If you press  /  and the speaker light flashes and you do not hear dial tone, the Set Audio option has been used to set up the phone for headset use; press  /  a second time. If the light goes out, the phone is set up to be used only with a headset or handset. If the light stays on steady and you hear dial tone, you can alternate between the speakerphone and the headset by pressing  / . See the section **"Customizing your phone"** for instructions on how to change the **Set Audio** feature.

Why is my display blank?

Ensure that power is being provided to your phone. If your Network does not provide Inline power over Ethernet, you can obtain an additional accessory, the a PoE inline power supply, to provide power over Ethernet locally to your phone. See the section **"Connecting to the Network and to Power"** for details.

Why can I only see 4 options when the installer or user guide says there are more?

The telephone screen will only show 4 options at a time. To see more, press the down arrow button .

How do I remove the stand from the phone?

Place one hand on top of the phone, and place the other hand on the top of the stand. Pull the stand away from the telephone. You will have to pull quite forcefully, but this will not break the stand.

Can I turn the light on the screen off?

No. You can only adjust the contrast of the display.

Why does the telephone wobble?

Make sure the cords are routed properly through the stand, as indicated in the Installation section. Check that the stand has been properly snapped into place.

What is a softkey?

There are three keys on both the left and right side of the display. They do different things, depending on the command displayed next to them. See the section **"Softkeys"** under the **"Other Phone Features"** section in this manual, or refer to your **480i Operating Guide** for more information.

Limited Warranty

Aastra Telecom warrants this product against defects and malfunctions during a one (1) year period from the date of original purchase. If there is a defect or malfunction, Aastra Telecom shall, at its option, and as the exclusive remedy, either repair or replace the telephone set at no charge, if returned within the warranty period.

If replacement parts are used in making repairs, these parts may be refurbished, or may contain refurbished materials. If it is necessary to replace the telephone set, it may be replaced with a refurbished telephone of the same design and color. If it should become necessary to repair or replace a defective or malfunctioning telephone set under this warranty, the provisions of this warranty shall apply to the repaired or replaced telephone set until the expiration of ninety (90) days from the date of pick up, or the date of shipment to you, of the repaired or replacement set, or until the end of the original warranty period, whichever is later. Proof of the original purchase date is to be provided with all telephone sets returned for warranty repairs.

Exclusions

Aastra Telecom does not warrant its telephone sets to be compatible with the equipment of any particular telephone company. This warranty does not extend to damage to products resulting from improper installation or operation, alteration, accident, neglect, abuse, misuse, fire or natural causes such as storms or floods, after the telephone is in your possession.

Aastra Telecom shall not be liable for any incidental or consequential damages, including, but not limited to, loss, damage or expense directly or indirectly arising from the customers use of or inability to use this telephone, either separately or in combination with other equipment. This paragraph, however, shall not apply to consequential damages for injury to the

person in the case of telephones used or bought for use primarily for personal, family or household purposes.

This warranty sets forth the entire liability and obligations of Aastra Telecom with respect to breach of warranty, and the warranties set forth or limited herein are the sole warranties and are in lieu of all other warranties, expressed or implied, including warranties or fitness for particular purpose and merchantability.

Warranty Repair Services

Should the set fail during the warranty period;

In North America, please call 1-800-574-1611 for further information.

Outside North America, contact your sales representative for return instructions.

You will be responsible for shipping charges, if any. When you return this telephone for warranty service, you must present proof of purchase.

After Warranty Service

Aastra Telecom offers ongoing repair and support for this product. This service provides repair or replacement of your Aastra Telecom product, at Aastra Telecom's option, for a fixed charge. You are responsible for all shipping charges. For further information and shipping instructions;

In North America, contact our service information number: 1-800-574-1611.

Outside North America, contact your sales representative.

Note: Repairs to this product may be made only by the manufacturer and its authorized agents, or by others who are legally authorized. This restriction applies during and after the warranty period. Unauthorized repair will void the warranty.



Index

A

Accessories 2

B

Backlit Display 3

C

Conf. Key 4

Connecting

 Handset 7

 Headset (Optional) 7

Connecting to the Network
and to Power 6

Customizing your phone 9

D

Desk or Wall Installation

 Desk 7

 Wall 8

Direct Network Connection 5

Direct or Shared

Network Connection 5

H

Handsfree calling 4

I

Icom Key 4

Inline Power

 Not Provided 6

 Power Provided 6

Inserting Number Card 8

Installation and Setup 4,5

K

Key Description 3

L

Line Keys 4

M

Making and Receiving
Calls using a Headset 11

O

Option Key 4

Options

 Setting your Options 9

 Time Server 9

 Time Format 9

 Date Format 9

 Time Zone 9

 Daylight Saving 9

 Set Ring Tone 9

 Clear Message Waiting 10

 Contrast Level 10

 Live Dial Pad 10

 Set Audio 10

 Status Lights 11

 Speaker Light 11

 Telephone Light 11

 Timer 11

R

Redial key 4

S

Services key 4,12

Shared Network Connection 5

Soft Keys 11,12

T

Troubleshooting 12

V

Volume

 Key 4

 Headset 11

 Handset 10

 Ringer 10

 Speaker 11

W

Warranty 13

X

Xfer Key 4

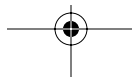



480i E Cover.fm Page 0 Tuesday, May 18, 2004 12:03 PM





480i E Cover.fm Page 0 Tuesday, May 18, 2004 12:03 PM



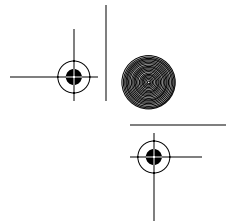
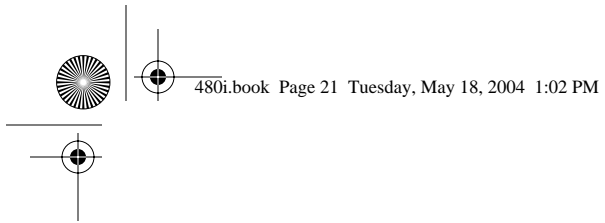

If you've read this owner's manual and consulted the Troubleshooting section and still have problems, please visit our website at www.aastra.com or call 1-800-574-1611 for technical assistance.

© Aastra Telecom Inc. 2004 41-0062-00 Rev 00

